

# MasterSheet

050 0021  
Revision 01/18/11



Complete Car Audio  
Installation Instructions  
**CRUTCHFIELD™**

## IMPORTANT

Before starting, compare items on your invoice with items received. Carefully check through packaging material. If any item is missing, please call **Crutchfield Technical Support at 1-800-955-9094**.

**2003-08  
Subaru Forester**



## Inside...

Although reasonable attempts are made to verify the accuracy of the information contained in this MasterSheet, it is presented without warranties or guarantees of any type due to the constantly changing nature of this type of information and running changes in vehicle production. Any person or entity using this information does so at his or its own risk. If you find our instructions are different from your vehicle, or if you have questions, do not continue with your installation. Contact our toll-free technical support for assistance.

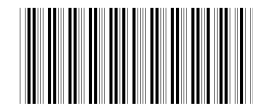



\*0000500021\*

### Page

2-3	Factory Radio Removal	✓	✓	✓	
4	Receiver Installation (w/o factory CD changer)	✓			
5	Receiver Installation (with factory CD changer)	✓		✓	
6-7	Front Door Speakers	✓	✓	✓	✓
8-9	Rear Door Speakers	✓	✓	✓	✓

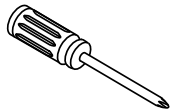
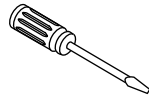
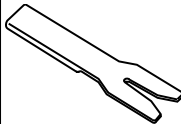
## Tools Required ▶

Phillips Screwdriver	Small Flat Blade Screwdriver	Panel Tool	Drill & 1/8" Bit
			

\* If you need additional wiring information, visit us online at [www.crutchfield.com/support/faq.html](http://www.crutchfield.com/support/faq.html)

**Note:** At this time, no aftermarket antenna is available from Crutchfield. A replacement antenna may be purchased from a local dealership.

**CRUTCHFIELD®**  
CRUTCHFIELD.COM

Copyright 2011 Crutchfield Corporation

050 0021

# Factory Radio Removal

1. Set parking brake.
2. Before proceeding, eject disc(s) from factory unit if present.
3. Disconnect negative battery cable to prevent any electrical short.
4. The gear shift must be moved to the lowest position. This can be done (when the ignition switch is off) by prying up the tab in the top right of the gear shift trim and depressing the exposed button to release the gear shift lever (see Figure 2).
5. Pry around gear shift trim to release clips. Lift trim, disconnect harness and remove (Figure 1).
6. Remove two (2) phillips screws from bottom of receiver trimpanel (Figure 2).
7. *This step pertains to vehicles without automatic climate control. If vehicle has auto climate control, skip to step 8.* Press metal clip under passenger's side knee panel to release vent control cable. Press small white plastic clip at end to release cable (Figure 3). Use this same step to release temperature control cable under driver's side knee panel (Figure 4).

**Continued on the next page.**

 **1-800-955-9094**  
**TECHNICAL SUPPORT**

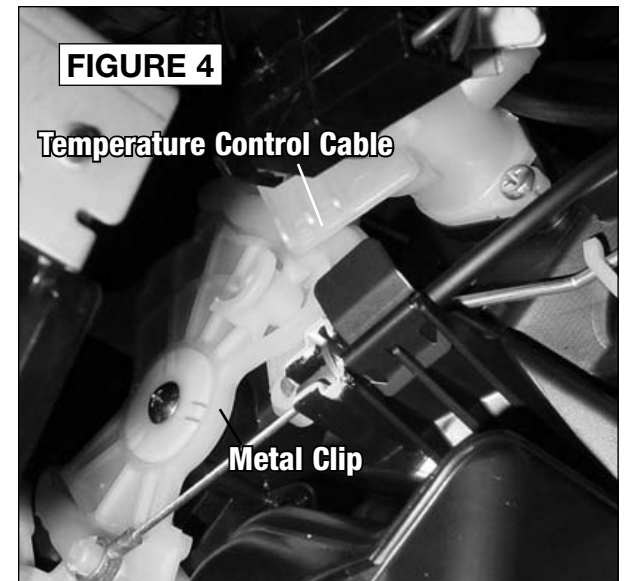
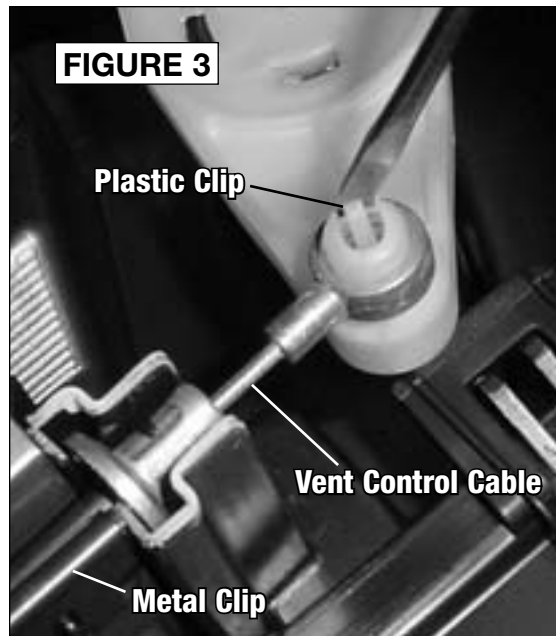
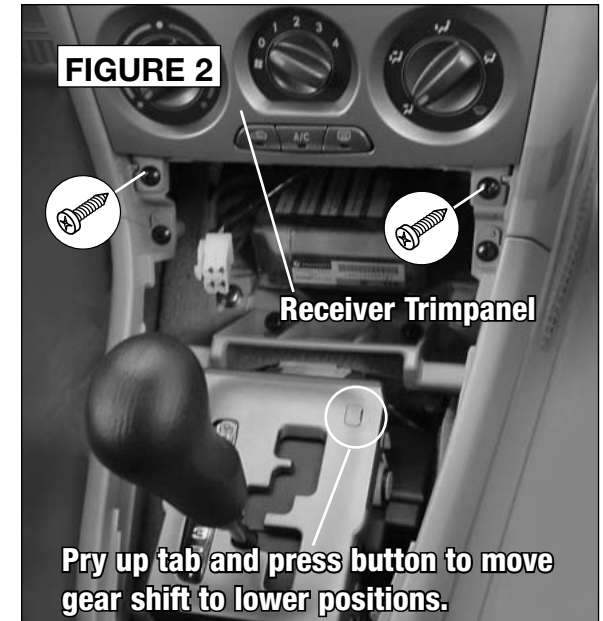

**CRUTCHFIELD**<sup>®</sup>  
CRUTCHFIELD.COM

Copyright 2011 Crutchfield Corporation

050 0021

## Factory Radio Removal (continued)

8. Pry around edges of receiver trimpanel to release clips (Figure 5). Pull out trimpanel, disconnect harnesses and work cables through openings. **Note:** Make note of cable routings for reinstallation. Remove trimpanel (Figure 6).
9. Remove four (4) phillips screws securing factory radio. Pull out radio, disconnect and remove (Figure 7).

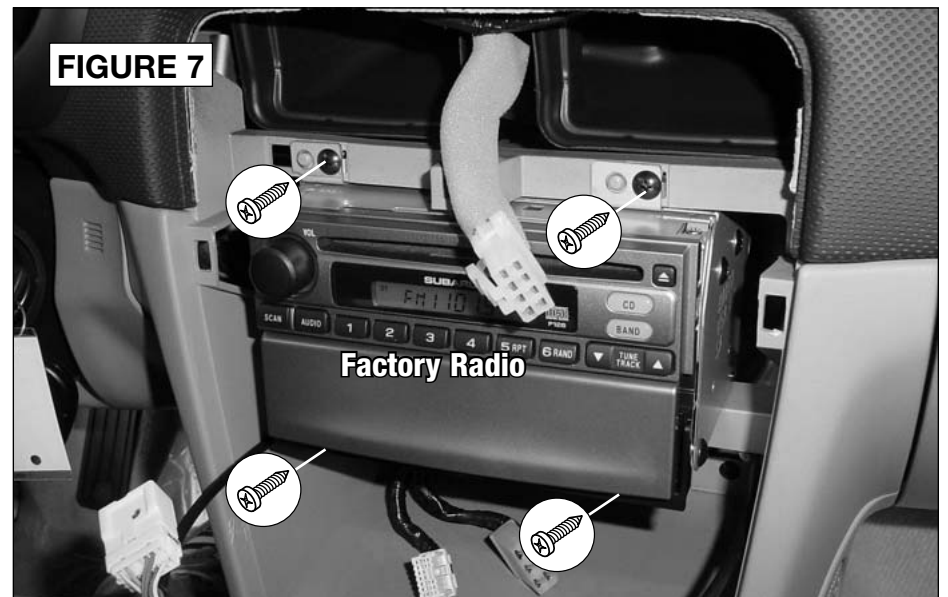



050 0021

# Receiver Installation (vehicle without factory CD changer)

## NOTES:

### Please read first

- Inspect factory receiver harness connector in vehicle. Ensure that the wiring adaptor received from Crutchfield plugs into the vehicle's connector. If the connector is missing or incorrect, please call our Technical Support Department at **1-800-955-9094**.

1. Remove DIN sleeve from receiver (Figure 1).  
**Note:** Sleeve will not be used in this application.
2. Remove two (2) screws from side brackets of factory radio (Figure 2). Remove radio.
3. Align mounting holes on sides of new receiver with holes in side brackets and secure receiver in same manner as factory radio using screws supplied with receiver (Figure 3).
4. Connect receiver wiring adaptor to receiver following instructions supplied with the adaptor.
5. Hold receiver assembly near dash. Connect receiver wiring adaptor to factory harness. Plug antenna lead into rear of receiver.
6. Slide assembly into dash and secure with screws previously removed.
7. Test receiver operation and reassemble dash by reversing removal steps.

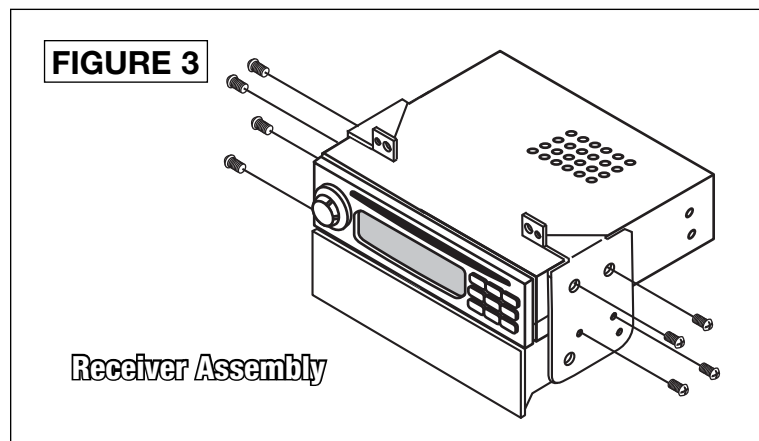
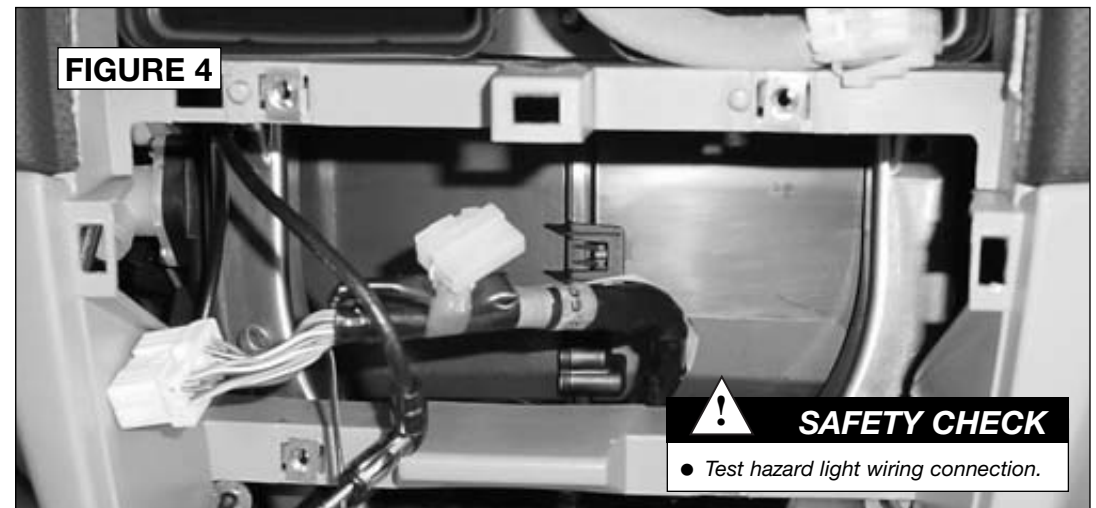
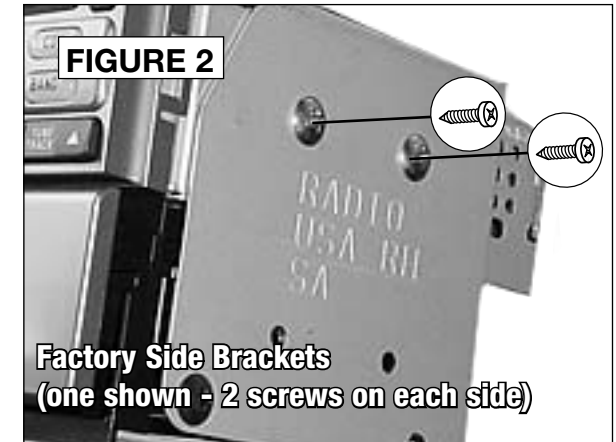
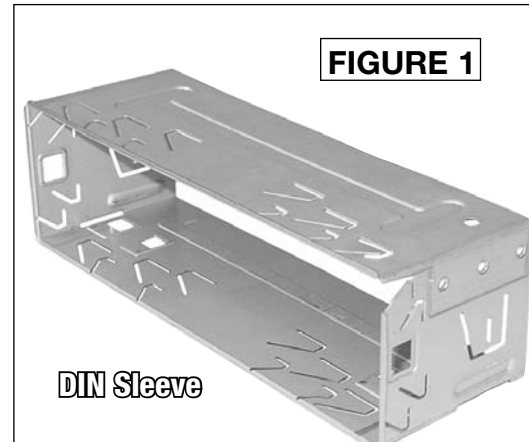

**1-800-955-9094**  
**TECHNICAL SUPPORT**

**CRUTCHFIELD**  
CRUTCHFIELD.COM

Copyright 2011 Crutchfield Corporation

# Receiver Installation (if vehicle is equipped with factory CD changer)

1. Remove DIN sleeve from new receiver (Figure 1).
2. Prepare pocket following instructions supplied with the pocket kit.
3. Remove six (6) phillips screws (three on each side) securing side brackets to factory receiver and remove brackets (Figure 2). **Note:** Brackets will be used for installation of new receiver.
4. Align top holes of factory side brackets with holes in sides of new receiver. Secure brackets to receiver with screws supplied with new receiver (Figure 3).
5. Align bottom holes in factory side brackets with screw holes in sides of pocket brackets. Secure pocket to side brackets using screws supplied with the installation kit (Figure 3).
6. Connect receiver wiring adaptor to receiver following instructions supplied with the adaptor.
7. Hold receiver assembly near dash. Connect receiver wiring adaptor to vehicle harness. Plug antenna lead into rear of receiver.
8. Slide assembly into dash and secure with screws previously removed.
9. Test receiver operation and reassemble dash by reversing disassembly steps.

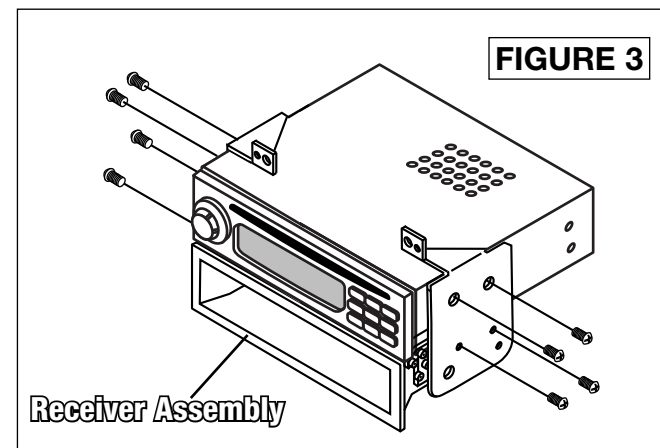
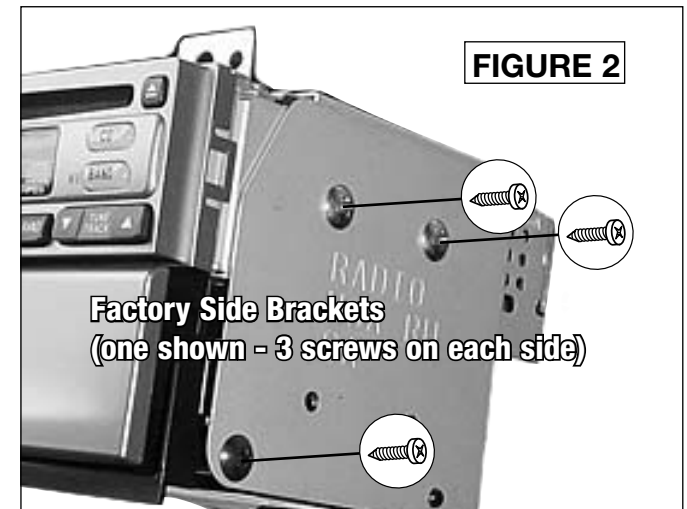
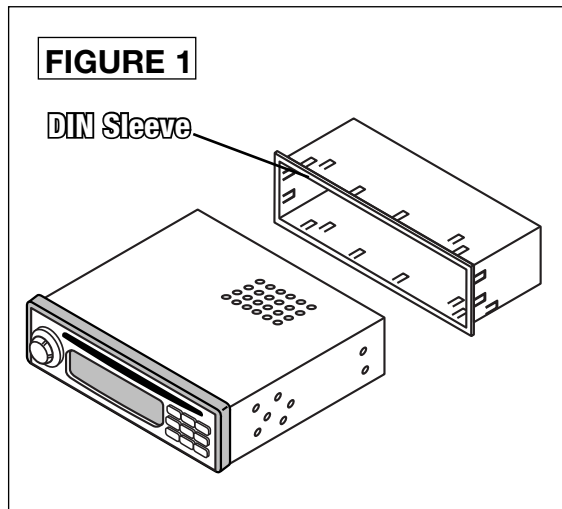

**1-800-955-9094**  
**TECHNICAL SUPPORT**



**SAFETY CHECK**

- Test hazard light wiring connection.

**CRUTCHFIELD**<sup>®</sup>  
CRUTCHFIELD.COM

Copyright 2011 Crutchfield Corporation

050 0021

# Front Door Speakers

## NOTES:

**Please read first**

- Instructions show factory size speakers or speakers with adaptor brackets only. Cutting or fabricating (not shown) will be required for other speaker sizes.



### IMPORTANT:

The speakers purchased may or may not be supplied with mounting screws and it may be necessary to acquire them.

1. Pry off "sail" panel to remove (Figure 1).
2. Pry off door release trim ring (Figure 2).
3. Pry open screw cover in bottom of door pull cup and remove exposed phillips screw (Figure 3).
4. Pry up power options switch panel, disconnect wiring harnesses and remove (Figures 4 & 5).

FIGURE 1

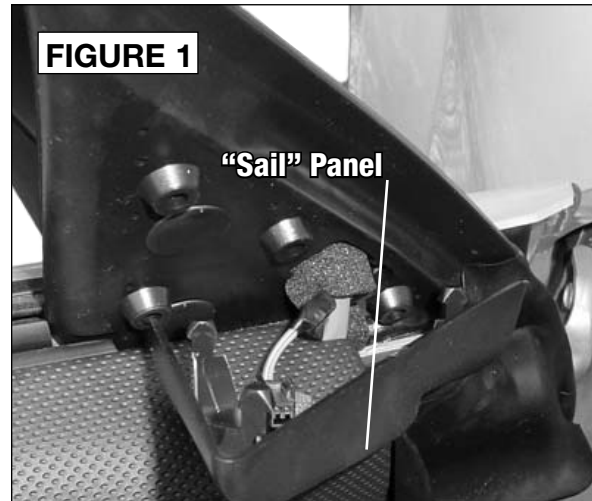

FIGURE 2



Continued on the next page.

FIGURE 3

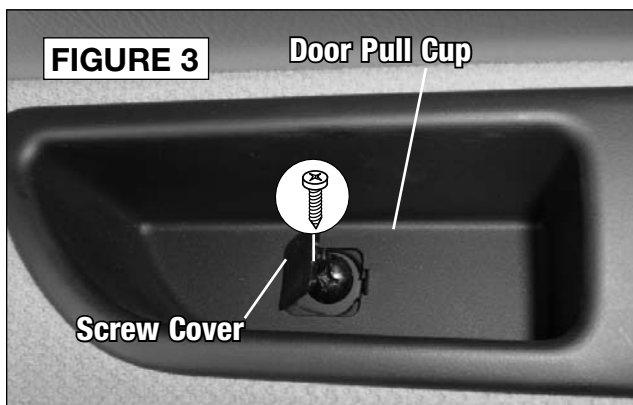
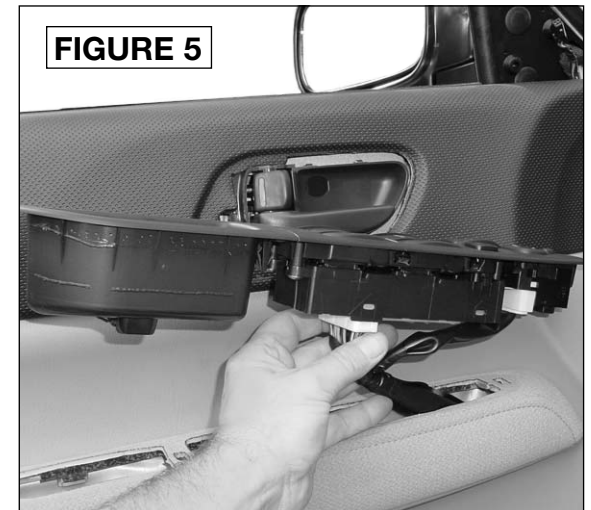

FIGURE 4



FIGURE 5



1-800-955-9094  
TECHNICAL SUPPORT

**CRUTCHFIELD**<sup>®</sup>  
CRUTCHFIELD.COM

Copyright 2011 Crutchfield Corporation



050 0021

## Front Door Speakers (continued)

5. Pry around sides and bottom of door panel to release clips. Lift panel and remove (Figure 6).
6. Disconnect speaker wiring harness. Remove three (3) phillips screws securing speaker. Pull out speaker to remove (Figure 7).
7. Place new speaker in location and use as a template to mark locations for new mounting holes. Remove speaker and drill holes with a 1/8" bit.
8. Connect speaker wiring adaptor of replacement speaker to vehicle speaker harness. Secure speaker.
9. Test speaker operation and reinstall door panel by reversing removal steps.

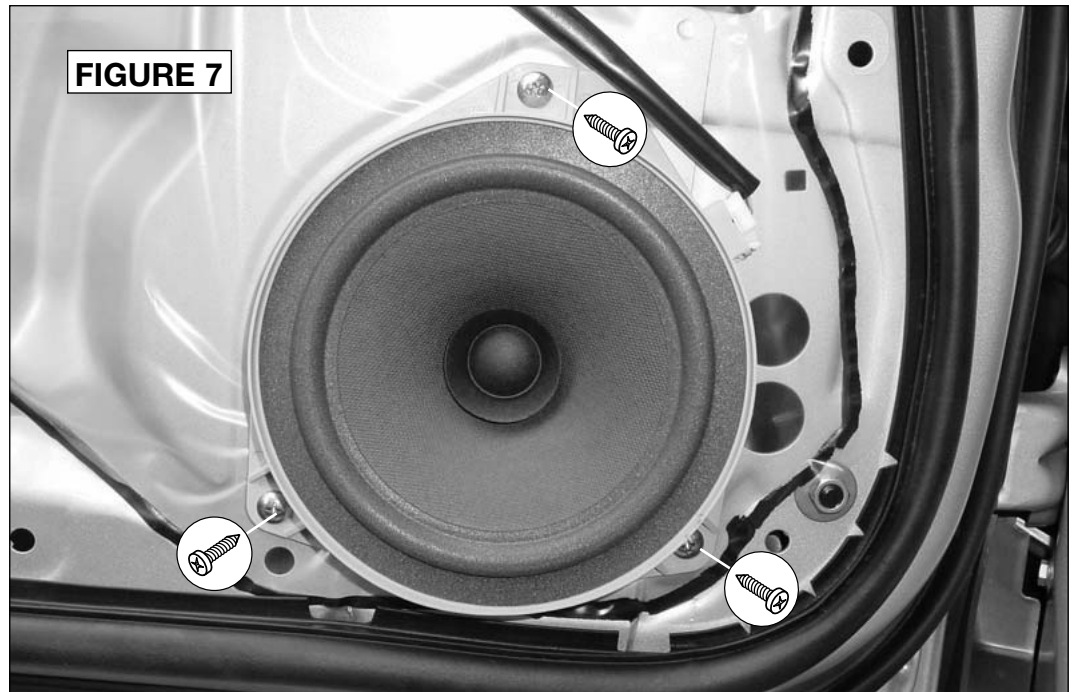

### CAUTION:

Always be careful when drilling or cutting in a vehicle. Be aware of things such as wiring, windows, fuel lines and safety devices. Check drilling/cutting depth and location to avoid damage or jeopardize safety.



### SAFETY CHECK

- Check that wires do not interfere with window operation.
- Test door lock and release operation.



**1-800-955-9094**  
**TECHNICAL SUPPORT**

**CRUTCHFIELD**<sup>®</sup>  
CRUTCHFIELD.COM

Copyright 2011 Crutchfield Corporation

050 0021

# Rear Door Speakers

## NOTES:

### *Please read first*

- Instructions show factory size speakers or speakers with adaptor brackets only. Cutting or fabricating (not shown) will be required for other speaker sizes.



### **IMPORTANT:**

The speakers purchased may or may not be supplied with mounting screws and it may be necessary to acquire them.

1. Pry off door release trim (Figure 1).
2. Pry open screw cover in bottom of door pull cup and remove exposed phillips screw (Figure 2).
3. Pry up power options switch panel, disconnect wiring harnesses and remove (Figure 3).

*Continued on the next page.*

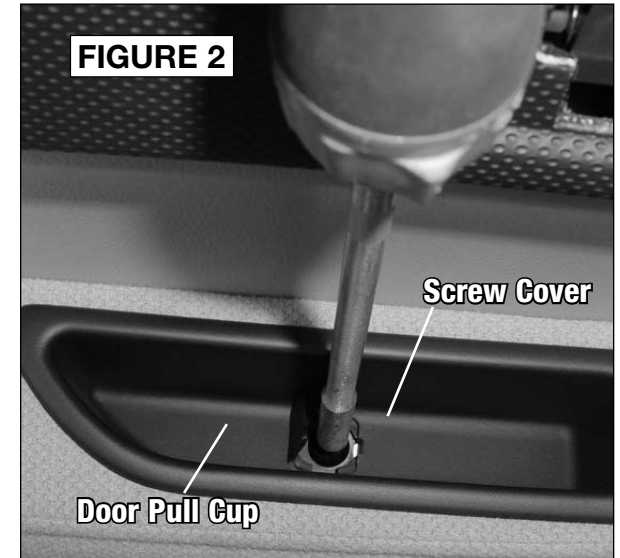

 **1-800-955-9094**  
TECHNICAL SUPPORT

**CRUTCHFIELD**<sup>®</sup>  
CRUTCHFIELD.COM

Copyright 2011 Crutchfield Corporation



050 0021

## Rear Door Speakers (continued)

4. Pry around sides and bottom of door panel to release clips. Lift panel and remove (Figure 4).
5. Remove three (3) phillips screws securing speaker. Pull out speaker, disconnect and remove (Figure 5).
6. Place new speaker in location and mark new mounting holes. Remove speaker and drill holes with a 1/8" bit.
7. Connect speaker wiring adaptor to vehicle speaker harness. Secure speaker and test operation.
8. Reinstall door panel by reversing removal steps.

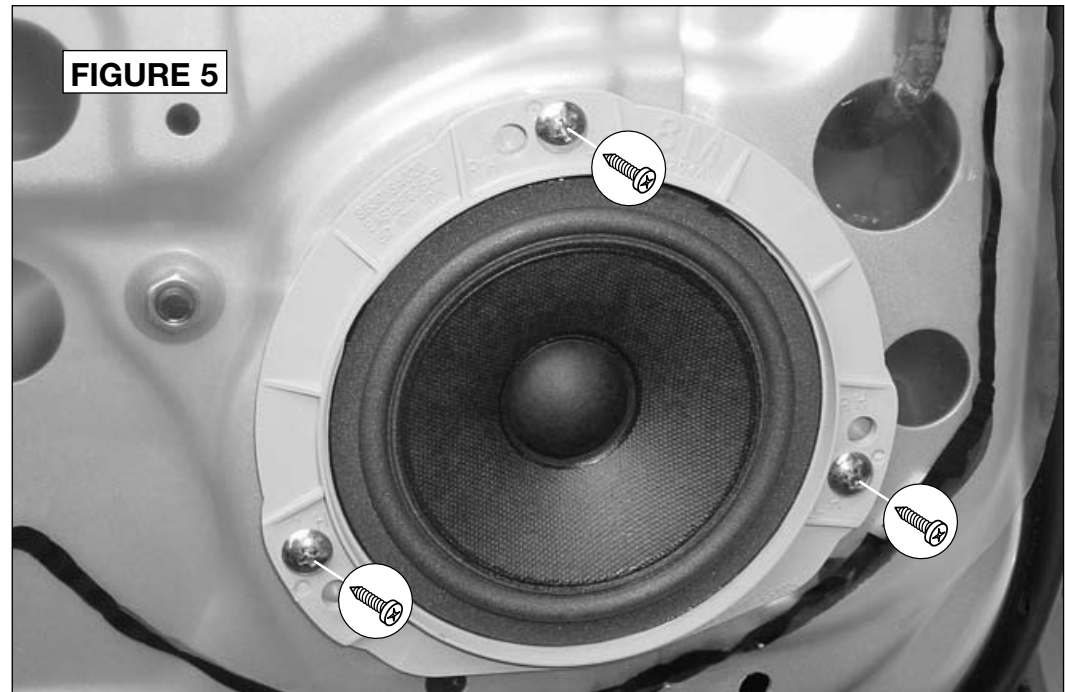

### IMPORTANT:

Always be careful when cutting or drilling in a vehicle. Be aware of things such as wiring, windows, fuel lines and safety devices. Check cutting/drilling depth and location to avoid damage or jeopardize safety.



### SAFETY CHECK

- Check that wires do not interfere with window operation.
- Test door lock and release operation.



1-800-955-9094  
TECHNICAL SUPPORT

**CRUTCHFIELD**  
CRUTCHFIELD.COM

Copyright 2011 Crutchfield Corporation